



DEPARTMENT OF REGULATORY AND ECONOMIC RESOURCES (RER)
BOARD AND CODE ADMINISTRATION DIVISION

MIAMI-DADE COUNTY
PRODUCT CONTROL SECTION
11805 SW 26 Street, Room 208
Miami, Florida 33175-2474
T (786) 315-2590 F (786) 315-2599

www.miamidade.gov/economy

NOTICE OF ACCEPTANCE (NOA)

Veka, Inc.
100 Veka Drive
Fombell, PA 16123

SCOPE:

This NOA is being issued under the applicable rules and regulations governing the use of construction materials. The documentation submitted has been reviewed and accepted by Miami-Dade County RER- Product Control Section to be used in Miami Dade County and other areas where allowed by the Authority Having Jurisdiction (AHJ).

This NOA shall not be valid after the expiration date stated below. The Miami-Dade County Product Control Section (In Miami Dade County) and/or the AHJ (in areas other than Miami Dade County) reserve the right to have this product or material tested for quality assurance purposes. If this product or material fails to perform in the accepted manner, the manufacturer will incur the expense of such testing and the AHJ may immediately revoke, modify, or suspend the use of such product or material within their jurisdiction. RER reserves the right to revoke this acceptance if it is determined by Miami-Dade County Product Control Section that this product or material fails to meet the requirements of the applicable building code.

This product is approved as described herein and has been designed to comply with the High Velocity Hurricane Zone of the Florida Building Code.

DESCRIPTION: PVC Privacy Fence Panels

APPROVAL DOCUMENT: Drawing No. NOA-Privfence, titled "PVC Privacy Fence", dated June 17, 2024, last revision #0 dated June 17, 2024, sheets 1 through 3 of 3, signed and sealed by Lucas A. Turner, P.E. on July 16, 2024, bearing the Miami-Dade County Product Control Revision stamp with the Notice of Acceptance number and the expiration date by the Miami-Dade County Product Control Section.

MISSILE IMPACT RATING: None

LABELING: Each fence panel shall bear a permanent label with the manufacturer's name or logo, city, state and the following statement: "Miami-Dade County Product Control Approved", unless otherwise noted herein.

RENEWAL of this NOA shall be considered after a renewal application has been filed and there has been no change in the applicable building code negatively affecting the performance of this product.

TERMINATION of this NOA will occur after the expiration date or if there has been a revision or change in the materials, use, and/or manufacture of the product or process. Misuse of this NOA as an endorsement of any product, for sales, advertising or any other purposes shall automatically terminate this NOA. Failure to comply with any section of this NOA shall be cause for termination and removal of NOA.

ADVERTISEMENT: The NOA number preceded by the words Miami-Dade County, Florida, and followed by the expiration date may be displayed in advertising literature. If any portion of the NOA is displayed, then it shall be done in its entirety.

INSPECTION: A copy of this entire NOA shall be provided to the user by the manufacturer or its distributors and shall be available for inspection at the job site at the request of the Building Official.

This NOA revises and renews NOA #21-0308.05 and consists of this page 1, evidence submitted pages E-1, E-2 & E-3 as well as approval document mentioned above.

The submitted documentation was reviewed by **Helmy A. Makar, P.E., M.S.**



Helmy A. Makar
10/03/24

NOA No. 24-0729.04
Expiration Date: 08/14/2029
Approval Date: 10/03/2024

Veka, Inc.

NOTICE OF ACCEPTANCE: EVIDENCE SUBMITTED

1. EVIDENCE SUBMITTED UNDER PREVIOUS APPROVAL # 14-0605.09

A. DRAWINGS

1. *Drawing No. S-4112, titled "PVC Privacy Fence", dated May 14, 2014, sheets 1 through 3 of 3, signed and sealed by Lyndon F. Schmidt, P.E. on June 09, 2014.*

B. TESTS

1. *Test Report # TEL 04401036, dated May 21, 2014, issued by Testing Evaluation Laboratories, Inc. for Series/Model 72" Tahoe II, PVC Fence Panels, signed and sealed by William B. Shelton, P.E. on May 27, 2014.*
2. *Test Report # TEL 04401035, dated May 21, 2014, revised on June 11, 2014, issued by Testing Evaluation Laboratories, Inc. for Series/Model 72" Shadowbox, PVC Fence Panels, signed and sealed by William B. Shelton, P.E. on June 11, 2014.*

C. CALCULATIONS

1. *Fence and Post Analysis, dated May 27, 2014, one sheet, signed and sealed by Lyndon F. Schmidt, P.E. on May 27, 2014.*

D. QUALITY ASSURANCE

1. *By Miami-Dade County Department of Regulatory and Economic Resources.*

E. MATERIAL CERTIFICATIONS

1. *NOA #12-0106.01 for the plastic material specifications.*

F. STATEMENTS

1. *FBC, 2010 Edition compliance letter issued by R W Building Consultants, Inc., dated May 27, 2014, signed and sealed by Lyndon F. Schmidt, P.E. on May 27, 2014.*

2. EVIDENCE SUBMITTED UNDER PREVIOUS APPROVAL # 16-0125.05

A. DRAWINGS

1. *Drawing No. S-4112, titled "PVC Privacy Fence", dated 05/14/14, last revision #1 dated 01/11/16, sheets 1 through 3 of 3, signed and sealed by Lyndon F. Schmidt, P.E. on 01/11/16.*

B. TESTS

1. *None.*

C. CALCULATIONS

1. *None.*

D. QUALITY ASSURANCE

1. *By Miami-Dade County Department of Regulatory and Economic Resources.*

E. MATERIAL CERTIFICATIONS

1. *None.*



Helmy A. Makar, P.E., M.S.
Product Control Section Supervisor
NOA No. 24-0729.04
Expiration Date: 08/14/2029
Approval Date: 10/03/2024

Veka, Inc.

NOTICE OF ACCEPTANCE: EVIDENCE SUBMITTED

F. STATEMENTS

1. *FBC, 2014 Edition compliance letter issued by R W Building Consultants, Inc., dated January 11, 2016, signed and sealed by Lyndon F. Schmidt, P.E.*

3. EVIDENCE SUBMITTED UNDER PREVIOUS APPROVAL # 18-1106.07

A. DRAWINGS

1. *Drawing No. S-4112, titled "PVC Privacy Fence", dated May 14, 2014, last revision #2 dated October 31, 2018, sheets 1 through 3 of 3, signed and sealed by Lyndon F. Schmidt, P.E. on October 31, 2018.*

B. TESTS

1. *None.*

C. CALCULATIONS

1. *None.*

D. QUALITY ASSURANCE

1. *By Miami-Dade County Department of Regulatory and Economic Resources.*

E. MATERIAL CERTIFICATIONS

1. *None.*

F. STATEMENTS

1. *FBC, 2017 Edition compliance letter issued by R W Building Consultants, Inc., dated October 31, 2018, signed and sealed by Lyndon F. Schmidt, P.E.*

4. EVIDENCE SUBMITTED UNDER PREVIOUS APPROVAL # 19-0829.02

A. DRAWINGS

1. *None.*

B. TESTS

1. *None.*

C. CALCULATIONS

1. *None.*

D. QUALITY ASSURANCE

1. *By Miami-Dade County Department of Regulatory and Economic Resources.*

E. MATERIAL CERTIFICATIONS

1. *None.*



Helmy A. Makar, P.E., M.S.
Product Control Section Supervisor
NOA No. 24-0729.04
Expiration Date: 08/14/2029
Approval Date: 10/03/2024

NOTICE OF ACCEPTANCE: EVIDENCE SUBMITTED

5. EVIDENCE SUBMITTED UNDER PREVIOUS APPROVAL # 21-0308.05

A. DRAWINGS

1. *Drawing No. S-4112, titled " PVC Privacy Fence ", dated May 14, 2014, last revision #3 dated March 01, 2021, sheets 1 through 3 of 3, signed and sealed by Lyndon F. Schmidt, P.E. on March 01, 2021.*

B. TESTS

1. *None.*

C. CALCULATIONS

1. *None.*

D. QUALITY ASSURANCE

1. *By Miami-Dade County Department of Regulatory and Economic Resources.*

E. MATERIAL CERTIFICATIONS

1. *None.*

F. STATEMENTS

1. *FBC, 2020 Edition compliance letter issued by R W Building Consultants, Inc., dated March 01, 2021, signed and sealed by Lyndon F. Schmidt, P.E.*

6. NEW EVIDENCE SUBMITTED

A. DRAWINGS

1. *Drawing No. NOA-Privfence, titled " PVC Privacy Fence ", dated June 17, 2024, last revision #0 dated June 17, 2024, sheets 1 through 3 of 3, signed and sealed by Lucas A. Turner, P.E. on July 16, 2024.*

B. TESTS

1. *None.*

C. CALCULATIONS

1. *Fence and Post Analysis, dated July 16, 2024, two sheets, signed and sealed by Lucas A. Turner, P.E. on July 16, 2024.*

D. QUALITY ASSURANCE

1. *By Miami-Dade County Department of Regulatory and Economic Resources.*

E. MATERIAL CERTIFICATIONS

1. *None.*

F. STATEMENTS

1. *FBC, 2023 Edition compliance letter issued by Turner Engineering & Consulting, Inc., dated July 16, 2024, signed and sealed by Lucas A. Turner, P.E.*

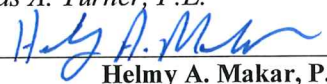

Helmy A. Makar, P.E., M.S.
Product Control Section Supervisor
NOA No. 24-0729.04
Expiration Date: 08/14/2029
Approval Date: 10/03/2024

VEKA PVC PRIVACY FENCE

GENERAL NOTES

1. THE PRODUCT SHOWN HEREIN IS DESIGNED AND MANUFACTURED TO COMPLY WITH THE REQUIREMENTS OF THE 8TH EDITION (2023) FLORIDA BUILDING CODE INCLUDING THE HIGH VELOCITY HURRICANE ZONE, IN ACCORDANCE WITH FBC SECT 1616.2.1, SEE WIND LOAD RATING NOTE BELOW.
2. INSTALLATION OF THIS FENCE SHALL BE IN ACCORDANCE WITH THIS UNMODIFIED PRODUCT APPROVAL DOCUMENT (P.A.D.), OR AS APPROVED ON A SITE-SPECIFIC BASIS BY A FLORIDA-LICENSED PROFESSIONAL ENGINEER OR ARCHITECT, WHICH WILL BECOME THE PROFESSIONAL OF RECORD (P.O.R.) FOR THE PROJECT AND WHO WILL BE RESPONSIBLE FOR THE PROPER USE OF THIS P.A.D.
3. THIS FENCE MANUFACTURER'S PERMANENT LABEL SHALL BE PLACED AT EACH FENCE ASSEMBLY. THE PERMANENT LABEL SHALL READ AS FOLLOWS:
VEKA, Inc.
Fombell, PA
Miami-Dade County
Product Control Approved
4. PRODUCT TESTED IN ACCORDANCE WITH MIAMI-DADE COUNTY PERFORMANCE TEST REQUIREMENTS AS SHOWN IN TEST REPORTS TEL 04401035 AND 04401036, ISSUED BY TESTING EVALUATION LABORATORY.
5. THE FENCE POST, RAILS, AND PICKETS ARE A COEXTRUDED MATERIAL WITH A MIN. 0.020" (+/- .005") CAP STOCK WITH UV INHIBITORS. ALL PARTS SHALL BE MADE OF PVC THAT IS MANUFACTURED BY VEKA, INC. REFER TO THE PVC MATERIAL SPECIFICATIONS SHOWN THIS SHEET FOR THE TESTED PROPERTIES.

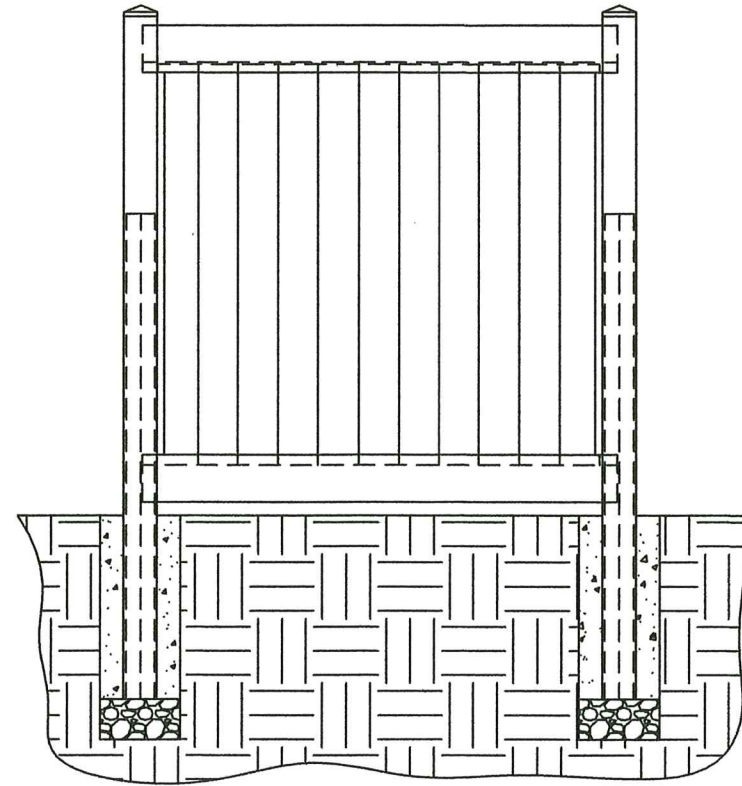

TAHOE II FENCE

SEE SHEET 2

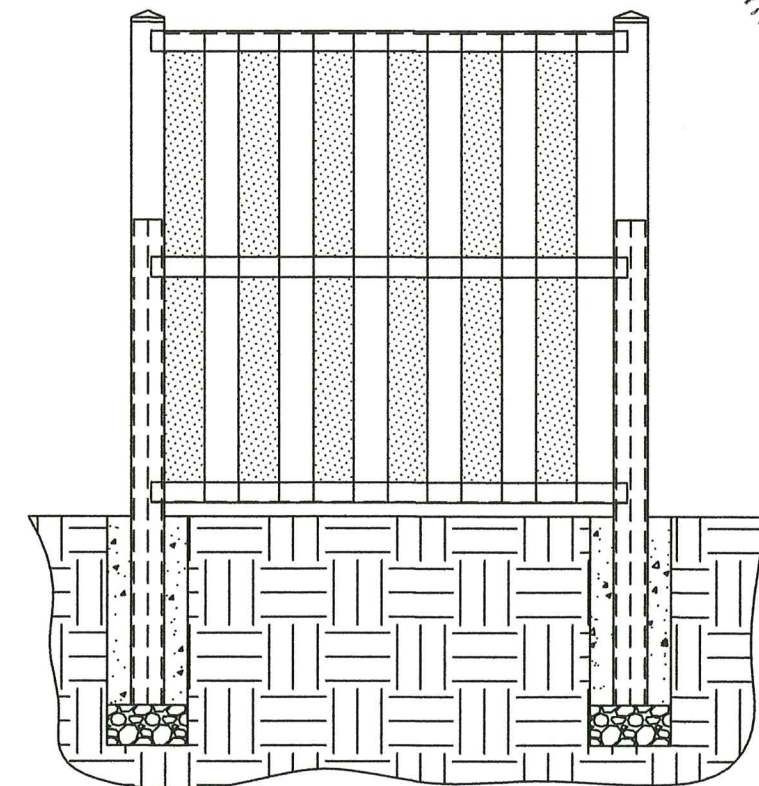

BRECKENRIDGE FENCE

SEE SHEET 3

WIND LOAD RATING

THIS FENCE AND ITS VERTICAL SUPPORTS ARE DESIGNED/TESTED FOR 75 MPH FASTEST MILE WIND SPEED OR 115 MPH 3-SECOND GUST IN COMPLIANCE WITH SECTION 1616.2.1 OF THE FLORIDA BUILDING CODE (DESIGN PRESSURE = 17.71 PSF)

PVC MATERIAL SPECIFICATIONS	TEST	PVC PROPERTIES
		WHITE
RATE OF BURNING	ASTM D635	CLASS CC1
SELF-IGNITION TEMPERATURE (SPONTANEOUS)	ASTM D1929	925°F > 650°F
AVERAGE SMOKE DENSITY RATING	ASTM D2843	43% < 75%
TENSILE STRENGTH (DIFFERENCE EXPOSED & UNEXPOSED)	ASTM D638	4.98% < 10%

PRODUCT REVISED
as complying with the Florida
Building Code
Acceptance No. 24-0729.04
Expiration Date 08/14/2029
By *[Signature]*
Miami Dade Product Control

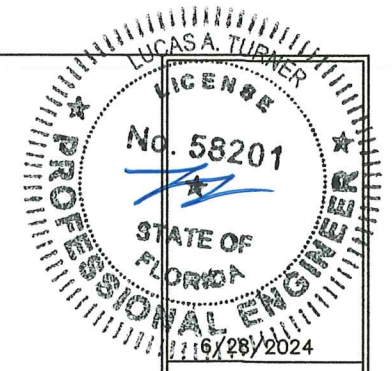

TE&C
LUCAS A. TURNER, P.E., FL PE 58201
TURNER ENGINEERING & CONSULTING, INC.
PH. 941-380-1574
2428 OLD NATCHEZ TRACE TRAIL
CAMDEN, TN 38320

VEKA, INC.
100 Veka Drive
Fombell, PA 16123



Product: PVC PRIVACY FENCE
REV 0 6/17/24 - INITIAL RELEASE
Date: 6/17/24
Scale: N.T.S.
Drawn: LAT

Dwg: NOA-PRIVFENCE
Sheet No. 1 OF 3

TABLE OF CONTENTS

SHEET #	DESCRIPTION
1	GEN. NOTES, WIND LOAD RATING, PVC PERFORMANCE
2	TAHOE II FENCE ELEV., DETAILS, PARTS, BOM
3	BRECKENRIDGE FENCE ELEV., DETAILS, PARTS, BOM

TAHOE II FENCE

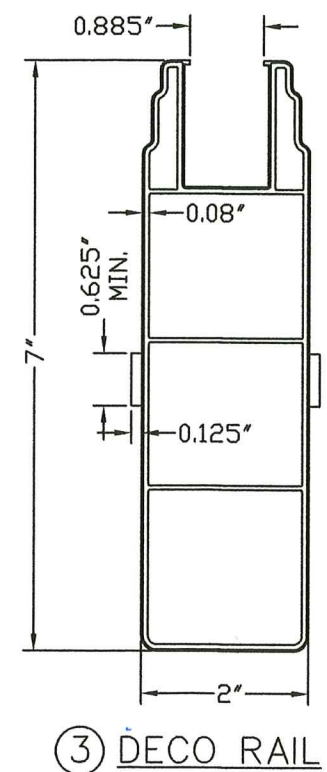
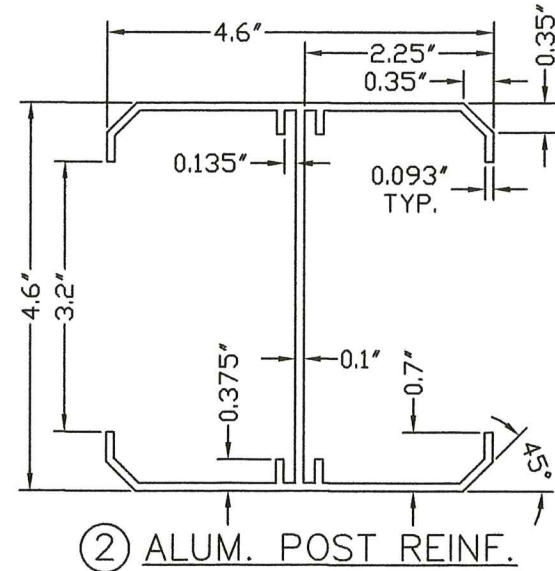
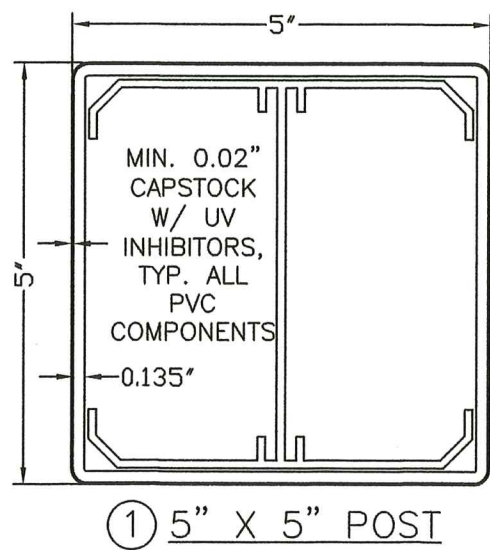
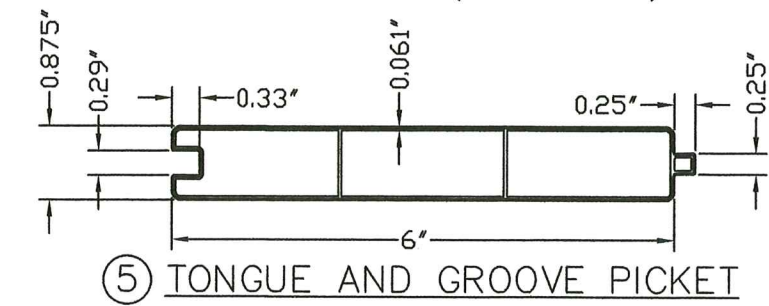
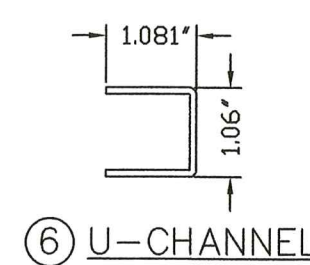
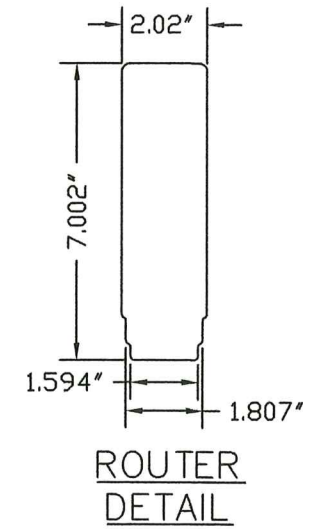
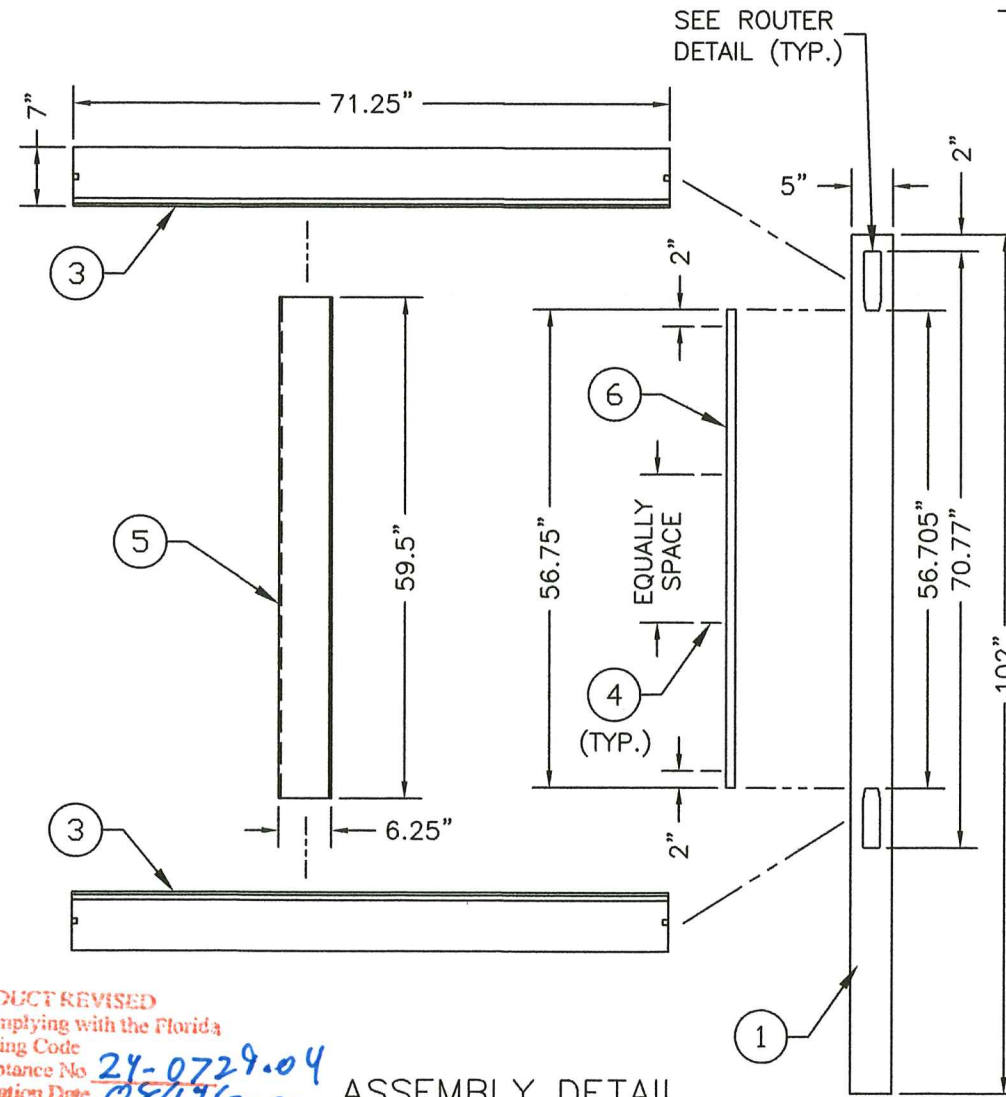
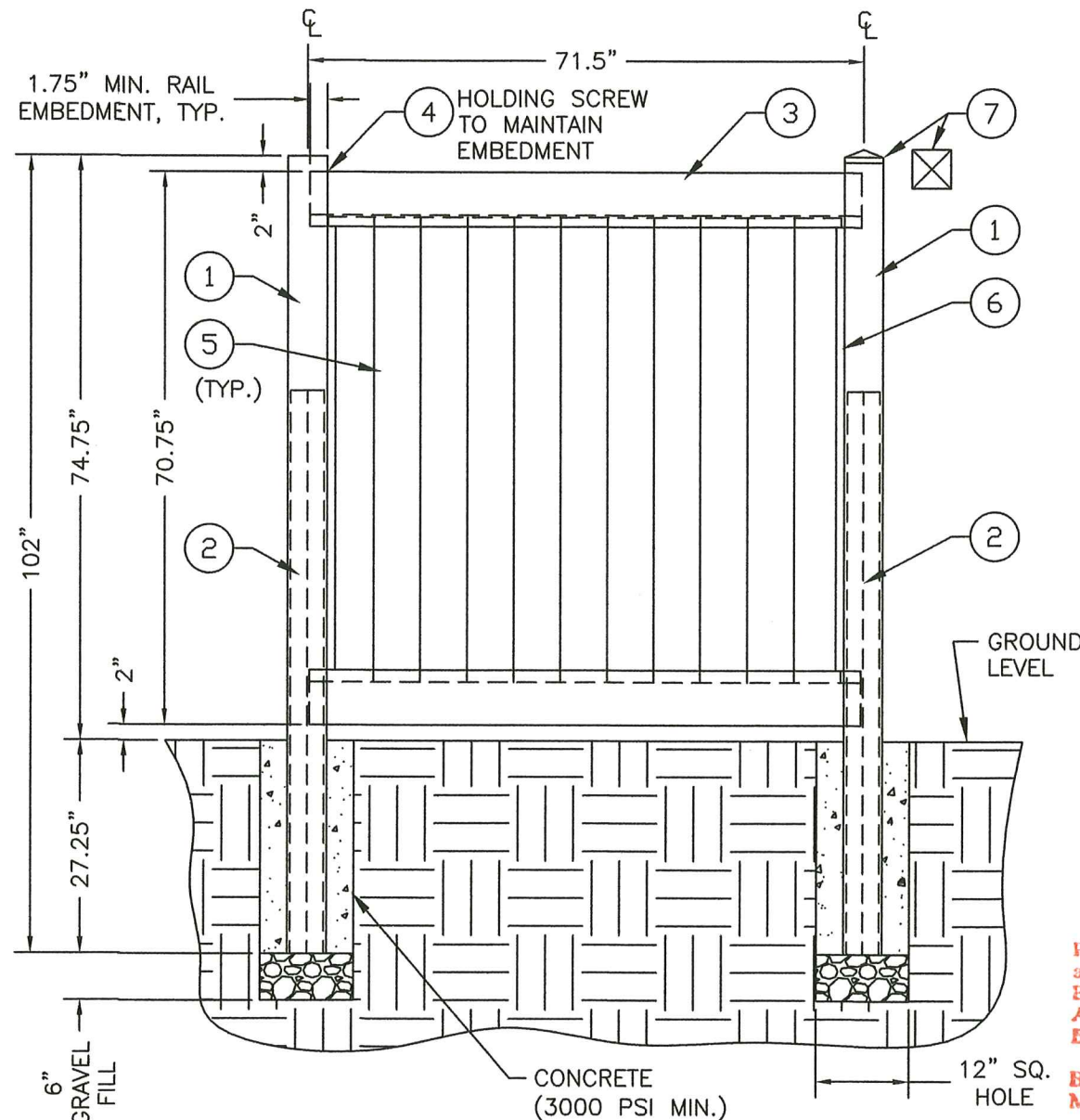

PRODUCT REVISED as complying with the Florida Building Code
 Acceptance No. 24-0729.04
 Expiration Date 05/19/2029
 By *[Signature]*
 Miami Dade Product Control

ASSEMBLY DETAIL

BILL OF MATERIALS		
ITEM #	DESCRIPTION	MATERIAL
1	5" X 5" POST	PVC
2	72" ALUMINUM POST REINFORCEMENT	6063-T6 ALUM.
3	DECO RAIL	PVC
4	#10 X 3/4" PPH SELF-DRILLING TEK SCREW	STEEL
5	TONGUE & GROOVE PICKET	PVC
6	U-CHANNEL	PVC
7	POST CAP	PVC

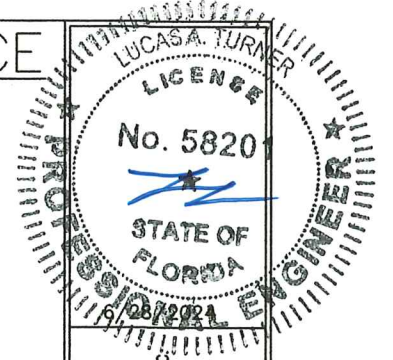

TE&C
 LUCAS A. TURNER, P.E. FL PE 58201
 TURNER ENGINEERING & CONSULTING, INC.
 PH. 941-390-1574
 2428 OLD NATCHEZ TRACE TRAIL
 CAMDEN, TN 38320

VEKA, INC.
 100 Veka Drive
 Fombell, PA 16123



Product: PVC PRIVACY FENCE
 REV 0 6/17/24 - INITIAL RELEASE
 Date: 6/17/24
 Scale: N.T.S.
 Drawn: LAT

Dwg: NOA-PRIVFENCE
 Sheet No. 2 OF 3

72" LONG, MUST BE INSERTED INTO EACH POST AND MUST EXTEND TO BOTTOM OF POST.

BRECKENRIDGE FENCE

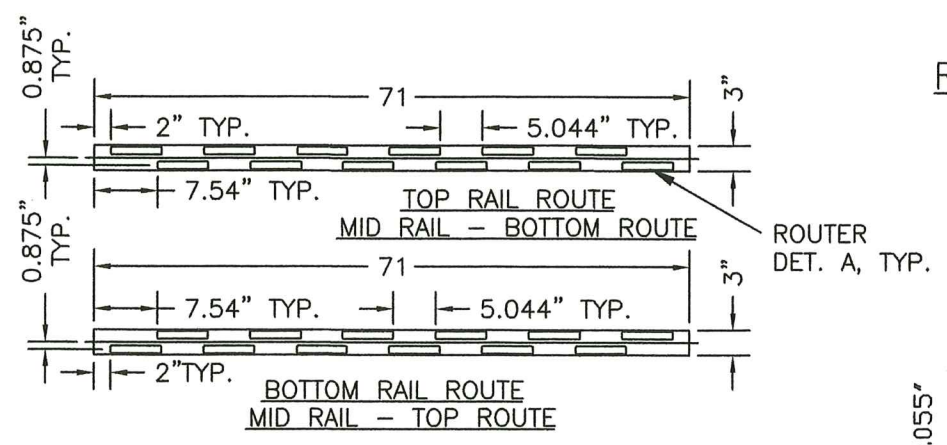
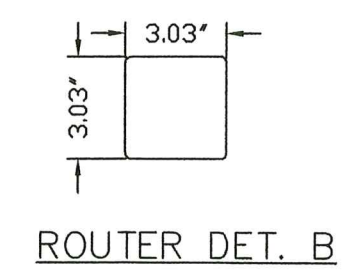
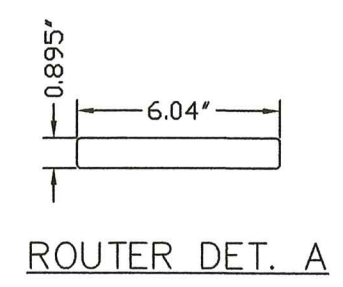
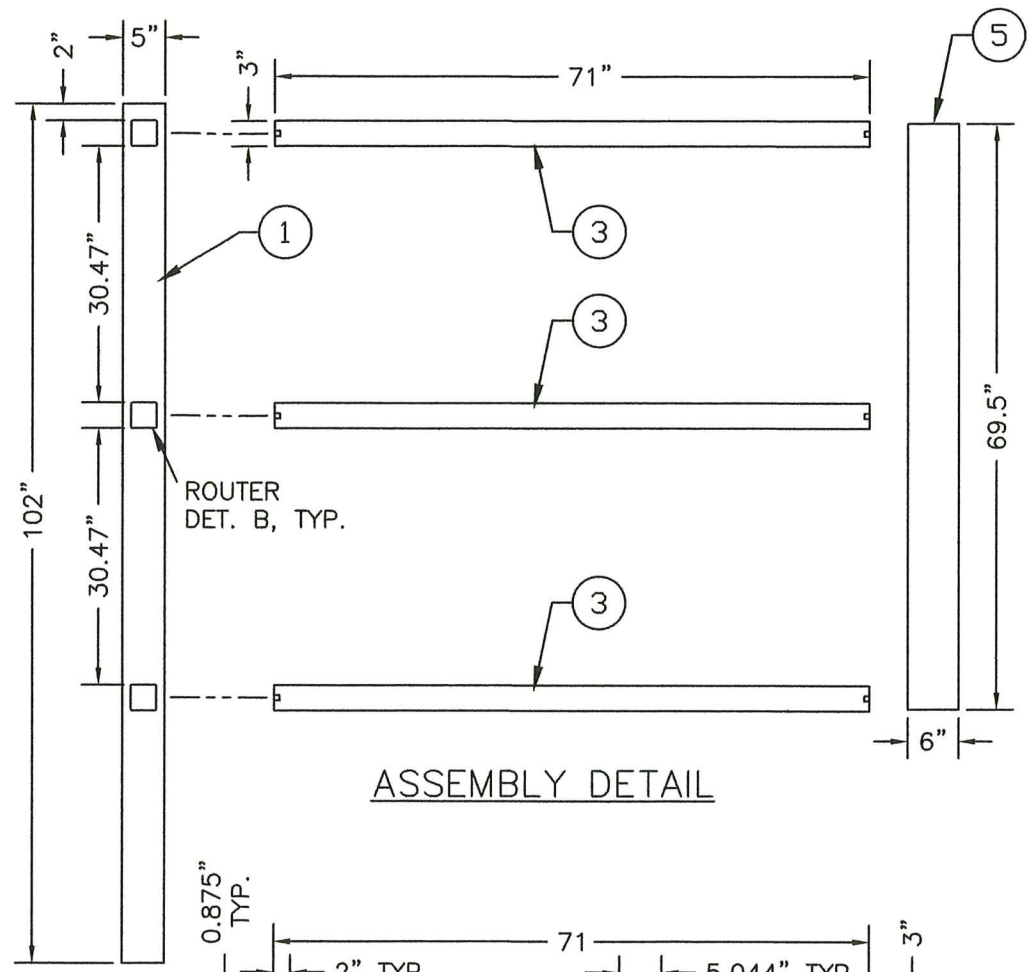
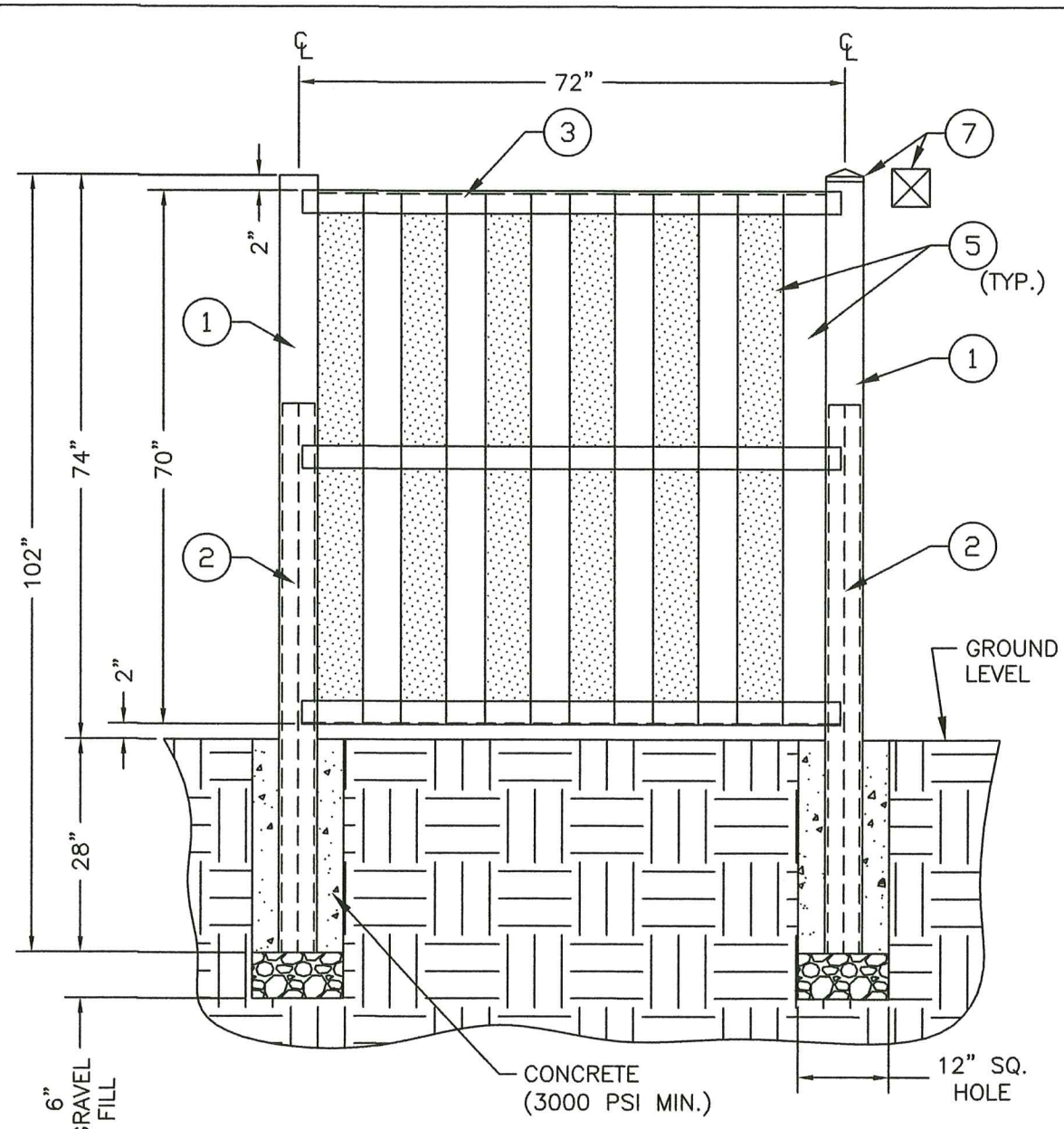

PRODUCT REVISED
 as complying with the Florida
 Building Code
 Acceptance No. 24-0729.04
 Expiration Date 05/14/2029
 By *Lucas A. Turner*
 Miami Date Product Control

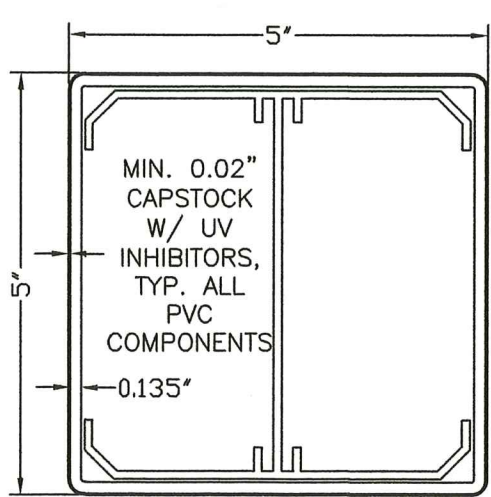

① 5" X 5" POST

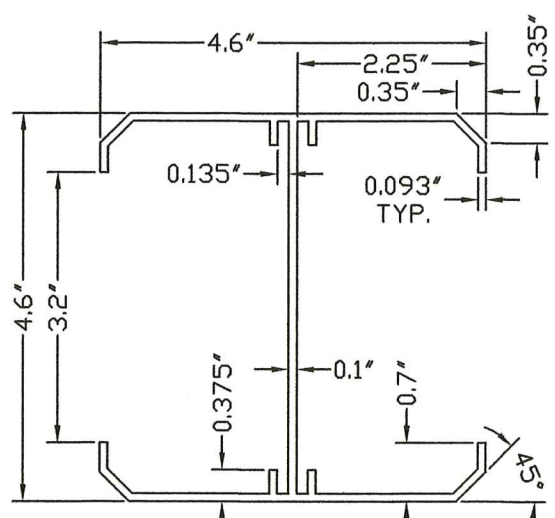

② ALUM. POST REINF.

72" LONG, MUST BE INSERTED INTO EACH POST AND MUST EXTEND TO BOTTOM OF POST.

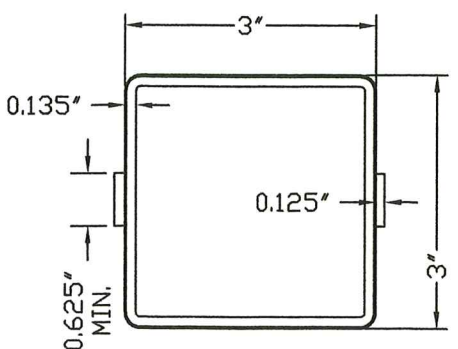

③ 3" X 3" RAIL

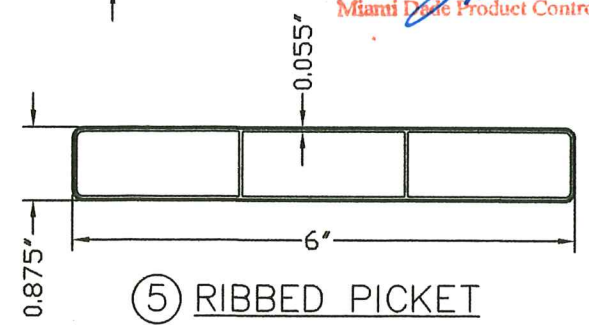

⑤ RIBBED PICKET

BILL OF MATERIALS		
ITEM #	DESCRIPTION	MATERIAL
1	5" X 5" POST	PVC
2	72" ALUMINUM POST REINFORCEMENT	6063-T6 ALUM.
3	3" X 3" RAIL	PVC
5	RIBBED PICKET	PVC
7	POST CAP	PVC

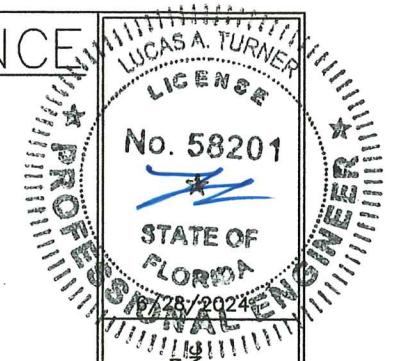

TE&C
 LUCAS A. TURNER, P.E. FL PE 58201
 TURNER ENGINEERING & CONSULTING, INC.
 PH. 941-380-1574
 2428 OLD NATCHEZ TRACE TRAIL
 CAMDEN, TN 38320

VEKA, INC.
 100 Veka Drive
 Fombell, PA 16123



Product: PVC PRIVACY FENCE
 REV 0 6/17/24 - INITIAL RELEASE
 Date: 6/17/24
 Scale: N.T.S.
 Drawn: LAT

Dwg: NOA-PRIVFENCE
 Sheet No. 3 OF 3